

The discrete form of Parseval's theorem is

$$\sum_{k=0}^{N-1} |h_k|^2 = \frac{1}{N} \sum_{n=0}^{N-1} |H_n|^2 \quad (12.1.10)$$

There are also discrete analogs to the convolution and correlation theorems (equations 12.0.9 and 12.0.11), but we shall defer them to §13.1 and §13.2, respectively.

CITED REFERENCES AND FURTHER READING:

Brigham, E.O. 1974, *The Fast Fourier Transform* (Englewood Cliffs, NJ: Prentice-Hall).
 Elliott, D.F., and Rao, K.R. 1982, *Fast Transforms: Algorithms, Analyses, Applications* (New York: Academic Press).

12.2 Fast Fourier Transform (FFT)

How much computation is involved in computing the discrete Fourier transform (12.1.7) of N points? For many years, until the mid-1960s, the standard answer was this: Define W as the complex number

$$W \equiv e^{2\pi i/N} \quad (12.2.1)$$

Then (12.1.7) can be written as

$$H_n = \sum_{k=0}^{N-1} W^{nk} h_k \quad (12.2.2)$$

In other words, the vector of h_k 's is multiplied by a matrix whose (n, k) th element is the constant W to the power $n \times k$. The matrix multiplication produces a vector result whose components are the H_n 's. This matrix multiplication evidently requires N^2 complex multiplications, plus a smaller number of operations to generate the required powers of W . So, the discrete Fourier transform appears to be an $O(N^2)$ process. These appearances are deceiving! The discrete Fourier transform can, in fact, be computed in $O(N \log_2 N)$ operations with an algorithm called the *fast Fourier transform*, or *FFT*. The difference between $N \log_2 N$ and N^2 is immense. With $N = 10^6$, for example, it is the difference between, roughly, 30 seconds of CPU time and 2 weeks of CPU time on a microsecond cycle time computer. The existence of an FFT algorithm became generally known only in the mid-1960s, from the work of J.W. Cooley and J.W. Tukey. Retrospectively, we now know (see [1]) that efficient methods for computing the DFT had been independently discovered, and in some cases implemented, by as many as a dozen individuals, starting with Gauss in 1805!

One "rediscovery" of the FFT, that of Danielson and Lanczos in 1942, provides one of the clearest derivations of the algorithm. Danielson and Lanczos showed that a discrete Fourier transform of length N can be rewritten as the sum of two discrete Fourier transforms, each of length $N/2$. One of the two is formed from the

even-numbered points of the original N , the other from the odd-numbered points. The proof is simply this:

$$\begin{aligned}
 F_k &= \sum_{j=0}^{N-1} e^{2\pi ijk/N} f_j \\
 &= \sum_{j=0}^{N/2-1} e^{2\pi ik(2j)/N} f_{2j} + \sum_{j=0}^{N/2-1} e^{2\pi ik(2j+1)/N} f_{2j+1} \\
 &= \sum_{j=0}^{N/2-1} e^{2\pi ikj/(N/2)} f_{2j} + W^k \sum_{j=0}^{N/2-1} e^{2\pi ikj/(N/2)} f_{2j+1} \\
 &= F_k^e + W^k F_k^o
 \end{aligned} \tag{12.2.3}$$

In the last line, W is the same complex constant as in (12.2.1), F_k^e denotes the k th component of the Fourier transform of length $N/2$ formed from the even components of the original f_j 's, while F_k^o is the corresponding transform of length $N/2$ formed from the odd components. Notice also that k in the last line of (12.2.3) varies from 0 to N , not just to $N/2$. Nevertheless, the transforms F_k^e and F_k^o are periodic in k with length $N/2$. So each is repeated through two cycles to obtain F_k .

The wonderful thing about the *Danielson-Lanczos Lemma* is that it can be used recursively. Having reduced the problem of computing F_k to that of computing F_k^e and F_k^o , we can do the same reduction of F_k^e to the problem of computing the transform of its $N/4$ even-numbered input data and $N/4$ odd-numbered data. In other words, we can define F_k^{ee} and F_k^{eo} to be the discrete Fourier transforms of the points which are respectively even-even and even-odd on the successive subdivisions of the data.

Although there are ways of treating other cases, by far the easiest case is the one in which the original N is an integer power of 2. In fact, we categorically recommend that you *only* use FFTs with N a power of two. If the length of your data set is not a power of two, pad it with zeros up to the next power of two. (We will give more sophisticated suggestions in subsequent sections below.) With this restriction on N , it is evident that we can continue applying the Danielson-Lanczos Lemma until we have subdivided the data all the way down to transforms of length 1. What is the Fourier transform of length one? It is just the identity operation that copies its one input number into its one output slot! In other words, for every pattern of $\log_2 N$ e 's and o 's, there is a one-point transform that is just one of the input numbers f_n

$$F_k^{eoeoeoe\cdots oee} = f_n \quad \text{for some } n \tag{12.2.4}$$

(Of course this one-point transform actually does not depend on k , since it is periodic in k with period 1.)

The next trick is to figure out which value of n corresponds to which pattern of e 's and o 's in equation (12.2.4). The answer is: Reverse the pattern of e 's and o 's, then let $e = 0$ and $o = 1$, and you will have, *in binary* the value of n . Do you see why it works? It is because the successive subdivisions of the data into even and odd are tests of successive low-order (least significant) bits of n . This idea of *bit reversal* can be exploited in a very clever way which, along with the Danielson-Lanczos

World Wide Web sample page from NUMERICAL RECIPES IN FORTRAN 77: THE ART OF SCIENTIFIC COMPUTING (ISBN 0-521-43064-X)
 Copyright (C) 1988-1992 by Cambridge University Press. Programs Copyright (C) 1988-1992 by Numerical Recipes Software.
 Permission is granted for internet users to make one paper copy for their own personal use. Further reproduction, or any copying of machine-readable files (including this one), to any server computer, is strictly prohibited. To order Numerical Recipes books, diskettes, or CDROMs visit website <http://www.nr.com> or call 1-800-872-7423 (North America only), or send email to trade@cup.cam.ac.uk (outside North America).

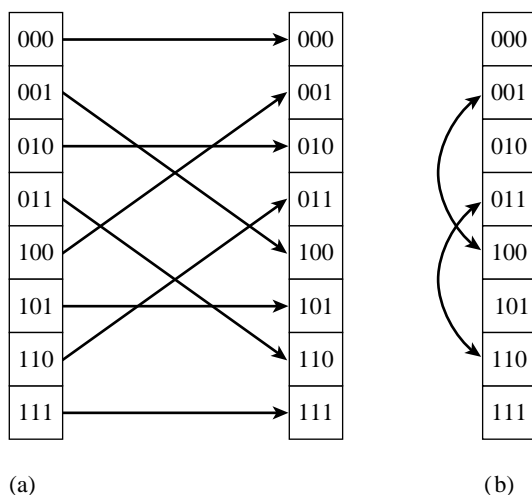

Figure 12.2.1. Reordering an array (here of length 8) by bit reversal, (a) between two arrays, versus (b) in place. Bit reversal reordering is a necessary part of the fast Fourier transform (FFT) algorithm.

Lemma, makes FFTs practical: Suppose we take the original vector of data f_j and rearrange it into bit-reversed order (see Figure 12.2.1), so that the individual numbers are in the order not of j , but of the number obtained by bit-reversing j . Then the bookkeeping on the recursive application of the Danielson-Lanczos Lemma becomes extraordinarily simple. The points as given are the one-point transforms. We combine adjacent pairs to get two-point transforms, then combine adjacent pairs of pairs to get 4-point transforms, and so on, until the first and second halves of the whole data set are combined into the final transform. Each combination takes of order N operations, and there are evidently $\log_2 N$ combinations, so the whole algorithm is of order $N \log_2 N$ (assuming, as is the case, that the process of sorting into bit-reversed order is no greater in order than $N \log_2 N$).

This, then, is the structure of an FFT algorithm: It has two sections. The first section sorts the data into bit-reversed order. Luckily this takes no additional storage, since it involves only swapping pairs of elements. (If k_1 is the bit reverse of k_2 , then k_2 is the bit reverse of k_1 .) The second section has an outer loop that is executed $\log_2 N$ times and calculates, in turn, transforms of length 2, 4, 8, \dots , N . For each stage of this process, two nested inner loops range over the subtransforms already computed and the elements of each transform, implementing the Danielson-Lanczos Lemma. The operation is made more efficient by restricting external calls for trigonometric sines and cosines to the outer loop, where they are made only $\log_2 N$ times. Computation of the sines and cosines of multiple angles is through simple recurrence relations in the inner loops (cf. 5.5.6).

The FFT routine given below is based on one originally written by N. M. Brenner. The input quantities are the number of complex data points (nn), the data array (data), and isign, which should be set to either ± 1 and is the sign of i in the exponential of equation (12.1.7). When isign is set to -1 , the routine thus calculates the inverse transform (12.1.9) — except that it does not multiply by the normalizing factor $1/N$ that appears in that equation. You can do that yourself.

Notice that the argument nn is the number of *complex* data points, although

we avoid the use of complex arithmetic because of the inefficient implementations found on many computers. The actual length of the real array (`data`) is 2 times `nn`, with each complex value occupying two consecutive locations. In other words, `data(1)` is the real part of f_0 , `data(2)` is the imaginary part of f_0 , and so on up to `data(2*nn-1)`, which is the real part of f_{N-1} , and `data(2*nn)`, which is the imaginary part of f_{N-1} . The FFT routine returns the F_n 's packed in exactly the same fashion, as `nn` complex numbers.

The real and imaginary parts of the zero frequency component F_0 are in `data(1)` and `data(2)`; the smallest nonzero positive frequency has real and imaginary parts in `data(3)` and `data(4)`; the smallest (in magnitude) nonzero negative frequency has real and imaginary parts in `data(2*nn-1)` and `data(2*nn)`. Positive frequencies increasing in magnitude are stored in the real-imaginary pairs `data(5)`, `data(6)` up to `data(nn-1)`, `data(nn)`. Negative frequencies of increasing magnitude are stored in `data(2*nn-3)`, `data(2*nn-2)` down to `data(nn+3)`, `data(nn+4)`. Finally, the pair `data(nn+1)`, `data(nn+2)` contain the real and imaginary parts of the one aliased point that contains the most positive and the most negative frequency. You should try to develop a familiarity with this storage arrangement of complex spectra, also shown in Figure 12.2.2, since it is the practical standard.

```

SUBROUTINE four1(data,nn,isign)
INTEGER isign,nn
REAL data(2*nn)
  Replaces data(1:2*nn) by its discrete Fourier transform, if isign is input as 1; or replaces
  data(1:2*nn) by nn times its inverse discrete Fourier transform, if isign is input as -1.
  data is a complex array of length nn or, equivalently, a real array of length 2*nn. nn
  MUST be an integer power of 2 (this is not checked for!).
INTEGER i,istep,j,m,mmax,n
REAL tempi,tempr
DOUBLE PRECISION theta,wi,wpi,wpr,wr,wtemp      Double precision for the trigonomet-
n=2*nn                                          ric recurrences.
j=1
do 11 i=1,n,2                                This is the bit-reversal section of the routine.
  if(j.gt.i)then
    tempr=data(j)                             Exchange the two complex numbers.
    tempi=data(j+1)
    data(j)=data(i)
    data(j+1)=data(i+1)
    data(i)=tempr
    data(i+1)=tempi
  endif
  m=n/2
1  if ((m.ge.2).and.(j.gt.m)) then
    j=j-m
    m=m/2
    goto 1
  endif
  j=j+m
enddo 11
mmax=2                                         Here begins the Danielson-Lanczos section of the routine.
2  if (n.gt.mmax) then                          Outer loop executed log2 nn times.
  istep=2*mmax
  theta=6.28318530717959d0/(isign*mmax)        Initialize for the trigonometric recur-
  wpr=-2.d0*sin(0.5d0*theta)**2                rence.
  wpi=sin(theta)
  wr=1.d0
  wi=0.d0
  do 13 m=1,mmax,2                             Here are the two nested inner loops.

```

World Wide Web sample page from NUMERICAL RECIPES IN FORTRAN 77: THE ART OF SCIENTIFIC COMPUTING (ISBN 0-521-43064-X)
 Copyright (C) 1988-1992 by Cambridge University Press. Programs Copyright (C) 1988-1992 by Numerical Recipes Software.
 Permission is granted for internet users to make one paper copy for their own personal use. Further reproduction, or any copying of machine-readable files (including this one), to any server computer, is strictly prohibited. To order Numerical Recipes books, diskettes, or CDROMs visit website <http://www.nr.com> or call 1-800-872-7423 (North America only), or send email to trade@cup.cam.ac.uk (outside North America).

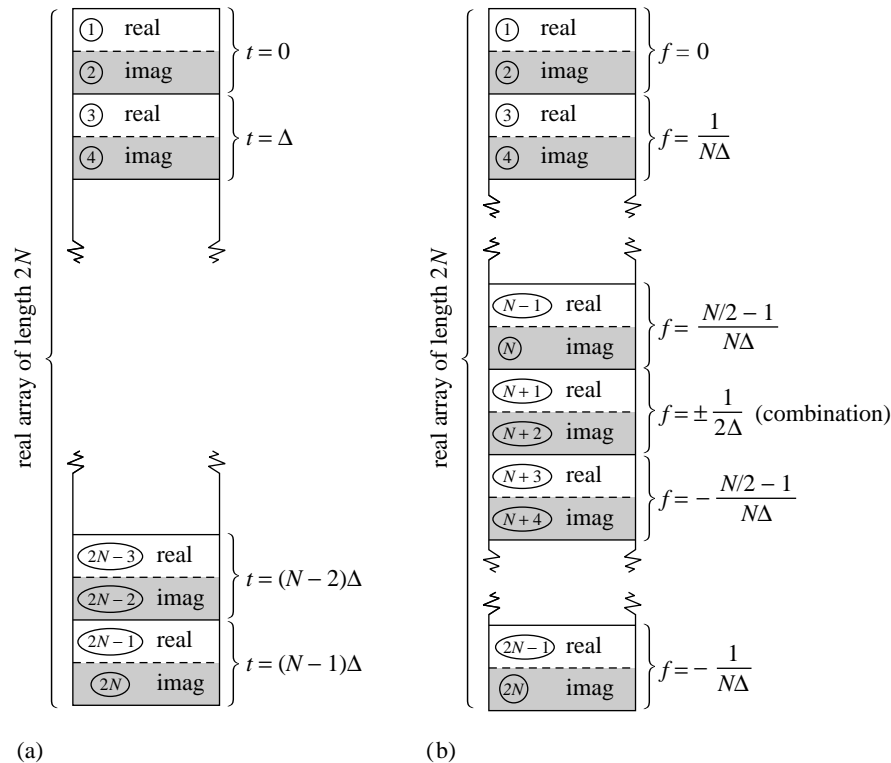

Figure 12.2.2. Input and output arrays for FFT. (a) The input array contains N (a power of 2) complex time samples in a real array of length $2N$, with real and imaginary parts alternating. (b) The output array contains the complex Fourier spectrum at N values of frequency. Real and imaginary parts again alternate. The array starts with zero frequency, works up to the most positive frequency (which is ambiguous with the most negative frequency). Negative frequencies follow, from the second-most negative up to the frequency just below zero.

```

do 12 i=m,n,istep
  j=i+mmax      This is the Danielson-Lanczos formula:
  tempr=sngl(wr)*data(j)-sngl(wi)*data(j+1)
  tempi=sngl(wr)*data(j+1)+sngl(wi)*data(j)
  data(j)=data(i)-tempr
  data(j+1)=data(i+1)-tempi
  data(i)=data(i)+tempr
  data(i+1)=data(i+1)+tempi
enddo 12
wtemp=wr      Trigonometric recurrence.
wr=wr*wpr-wi*wpi+wr
wi=wi*wpr+wtemp*wpi+wi
enddo 13
mmax=istep
goto 2      Not yet done.
endif      All done.
return
END

```

(A double precision version of `four1`, named `dfour1`, is used by the routine `mpmul` in §20.6. You can easily make the conversion, or else get the converted routine from the *Numerical Recipes* diskette.)

Other FFT Algorithms

We should mention that there are a number of variants on the basic FFT algorithm given above. As we have seen, that algorithm first rearranges the input elements into bit-reverse order, then builds up the output transform in $\log_2 N$ iterations. In the literature, this sequence is called a *decimation-in-time* or *Cooley-Tukey* FFT algorithm. It is also possible to derive FFT algorithms that first go through a set of $\log_2 N$ iterations on the input data, and rearrange the *output* values into bit-reverse order. These are called *decimation-in-frequency* or *Sande-Tukey* FFT algorithms. For some applications, such as convolution (§13.1), one takes a data set into the Fourier domain and then, after some manipulation, back out again. In these cases it is possible to avoid all bit reversing. You use a decimation-in-frequency algorithm (without its bit reversing) to get into the “scrambled” Fourier domain, do your operations there, and then use an inverse algorithm (without *its* bit reversing) to get back to the time domain. While elegant in principle, this procedure does not in practice save much computation time, since the bit reversals represent only a small fraction of an FFT’s operations count, and since most useful operations in the frequency domain require a knowledge of which points correspond to which frequencies.

Another class of FFTs subdivides the initial data set of length N not all the way down to the trivial transform of length 1, but rather only down to some other small power of 2, for example $N = 4$, *base-4 FFTs*, or $N = 8$, *base-8 FFTs*. These small transforms are then done by small sections of highly optimized coding which take advantage of special symmetries of that particular small N . For example, for $N = 4$, the trigonometric sines and cosines that enter are all ± 1 or 0, so many multiplications are eliminated, leaving largely additions and subtractions. These can be faster than simpler FFTs by some significant, but not overwhelming, factor, e.g., 20 or 30 percent.

There are also FFT algorithms for data sets of length N not a power of two. They work by using relations analogous to the Danielson-Lanczos Lemma to subdivide the initial problem into successively smaller problems, not by factors of 2, but by whatever small prime factors happen to divide N . The larger that the largest prime factor of N is, the worse this method works. If N is prime, then no subdivision is possible, and the user (whether he knows it or not) is taking a *slow* Fourier transform, of order N^2 instead of order $N \log_2 N$. Our advice is to stay clear of such FFT implementations, with perhaps one class of exceptions, the *Winograd Fourier transform algorithms*. Winograd has derived highly optimized codings for taking small- N discrete Fourier transforms, e.g., for $N = 2, 3, 4, 5, 7, 8, 11, 13, 16$. The algorithms also use a new and clever way of combining the subfactors. The method involves a reordering of the data both before the hierarchical processing and after it, but it allows a significant reduction in the number of multiplications in the algorithm. For some especially favorable values of N , the Winograd algorithms can be significantly (e.g., up to a factor of 2) faster than the simpler FFT algorithms of the nearest integer power of 2. This advantage in speed, however, must be weighed against the considerably more complicated data indexing involved in these transforms, and the fact that the Winograd transform cannot be done “in place.”

Finally, an interesting class of transforms for doing convolutions quickly are number theoretic transforms. These schemes replace floating-point arithmetic with

integer arithmetic modulo some large prime $N+1$, and the N th root of 1 by the modulo arithmetic equivalent. Strictly speaking, these are not *Fourier* transforms at all, but the properties are quite similar and computational speed can be far superior. On the other hand, their use is somewhat restricted to quantities like correlations and convolutions since the transform itself is not easily interpretable as a “frequency” spectrum.

CITED REFERENCES AND FURTHER READING:

- Nussbaumer, H.J. 1982, *Fast Fourier Transform and Convolution Algorithms* (New York: Springer-Verlag).
- Elliott, D.F., and Rao, K.R. 1982, *Fast Transforms: Algorithms, Analyses, Applications* (New York: Academic Press).
- Brigham, E.O. 1974, *The Fast Fourier Transform* (Englewood Cliffs, NJ: Prentice-Hall). [1]
- Bloomfield, P. 1976, *Fourier Analysis of Time Series – An Introduction* (New York: Wiley).
- Van Loan, C. 1992, *Computational Frameworks for the Fast Fourier Transform* (Philadelphia: S.I.A.M.).
- Beauchamp, K.G. 1984, *Applications of Walsh Functions and Related Functions* (New York: Academic Press) [non-Fourier transforms].
- Heideman, M.T., Johnson, D.H., and Burriss, C.S. 1984, *IEEE ASSP Magazine*, pp. 14–21 (October).

12.3 FFT of Real Functions, Sine and Cosine Transforms

It happens frequently that the data whose FFT is desired consist of real-valued samples f_j , $j = 0 \dots N - 1$. To use `four1`, we put these into a complex array with all imaginary parts set to zero. The resulting transform F_n , $n = 0 \dots N - 1$ satisfies $F_{N-n}^* = F_n$. Since this complex-valued array has real values for F_0 and $F_{N/2}$, and $(N/2) - 1$ other independent values $F_1 \dots F_{N/2-1}$, it has the same $2(N/2 - 1) + 2 = N$ “degrees of freedom” as the original, real data set. However, the use of the full complex FFT algorithm for real data is inefficient, both in execution time and in storage required. You would think that there is a better way.

There are *two* better ways. The first is “mass production”: Pack two separate real functions into the input array in such a way that their individual transforms can be separated from the result. This is implemented in the program `twofft` below. This may remind you of a one-cent sale, at which you are coerced to purchase two of an item when you only need one. However, remember that for correlations and convolutions the Fourier transforms of two functions are involved, and this is a handy way to do them both at once. The second method is to pack the real input array cleverly, without extra zeros, into a complex array of half its length. One then performs a complex FFT on this shorter length; the trick is then to get the required answer out of the result. This is done in the program `realft` below.